

# General information

## Cavity

Type series: GQ/C0840

### Dimensions and sectional view

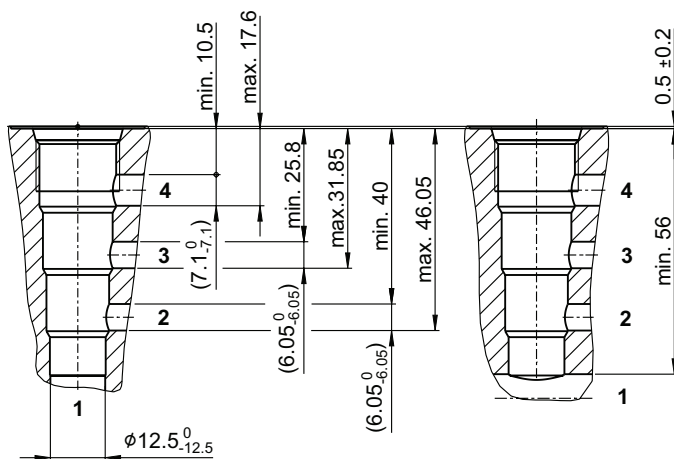
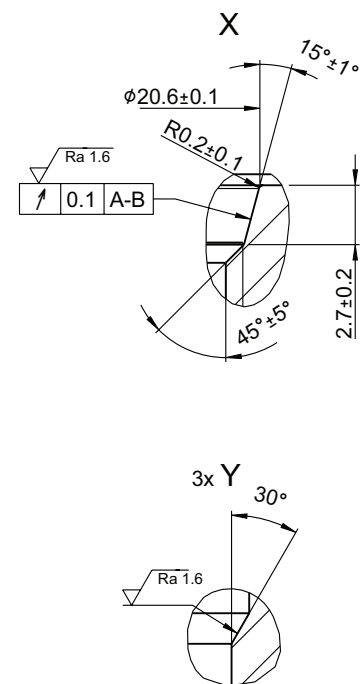
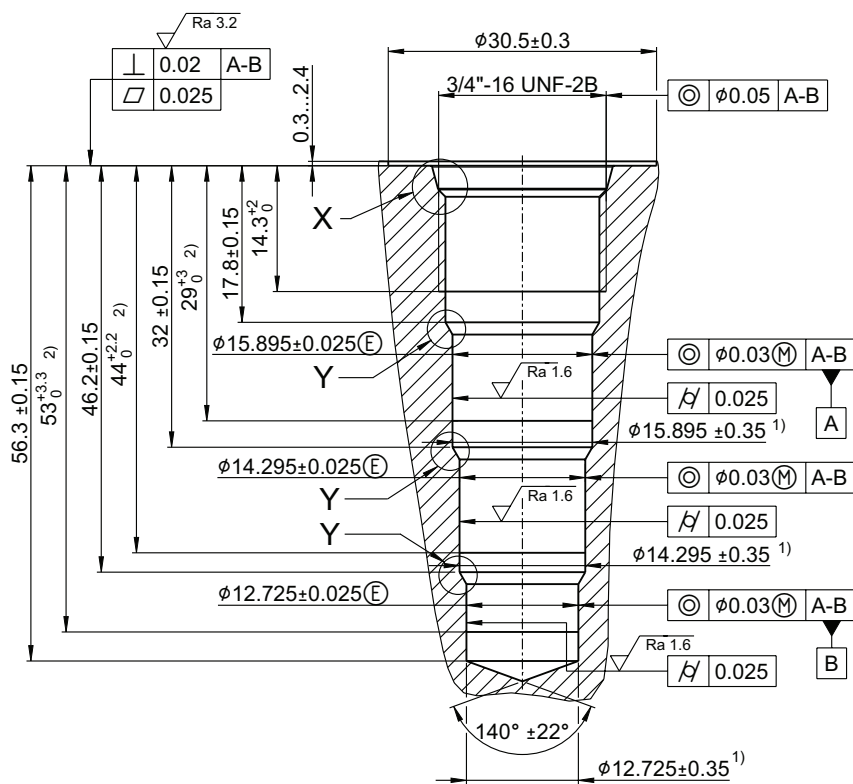

**i HINWEIS! / NOTE!**

- <sup>1)</sup> Passungstiefe / minimum depth of specified diametral tolerance
- <sup>2)</sup> Vorbearbeitungs- $\phi$  / pre-drilling diameters

## Installation information



### **ATTENTION!**

You must maintain the specified positional and diametral tolerances. To ensure trouble-free operation of the screw-in cartridges, we strongly recommend that pilot drilling, boring, reaming and cavity thread-cutting are always performed in one setup.



### **NOTE!**

The cavity type GQ/C0840 complies with the standard according to ISO 17209: 3/4-04-0-13 and NFPA/T3.5.50: 0.750-04-0-09.



### **NOTE!**

We offer form tool sets for sale or hire. For further information, see data sheet 400-P-040011.